

WYMIARY JEDNOSTEK ZEWNĘTRZNYCH

M-Thermal Split oraz ALL IN ONE – Wydajność 4-6 kW

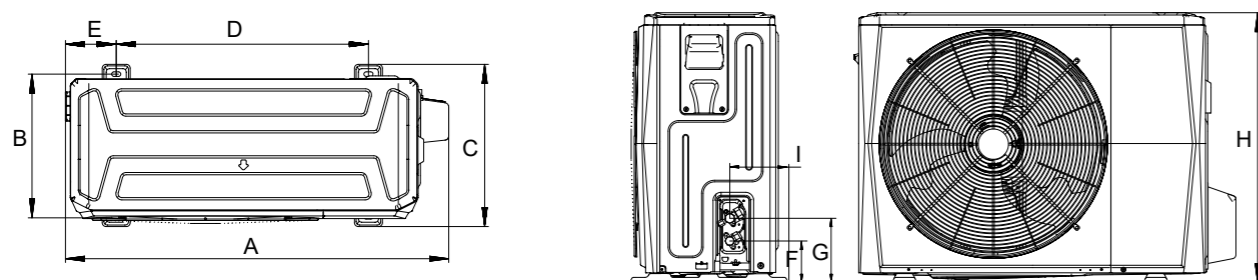

Model		MHA-V4W/D2N8-B MHA-V6W/D2N8-B
Wymiary A/H/C (dług./wys./głęb.)	mm	1008 / 712 / 426
Wymiary B/D/E	mm	375 / 663 / 134
Wymiary F/G/I	mm	110 / 170 / 160
Wymiary transportowe (dług./wys./głęb.)	mm	1065 / 810 / 485
Waga netto/brutto	kg	58 / 63,5

M-Thermal Split oraz ALL IN ONE – Wydajność 8-16 kW

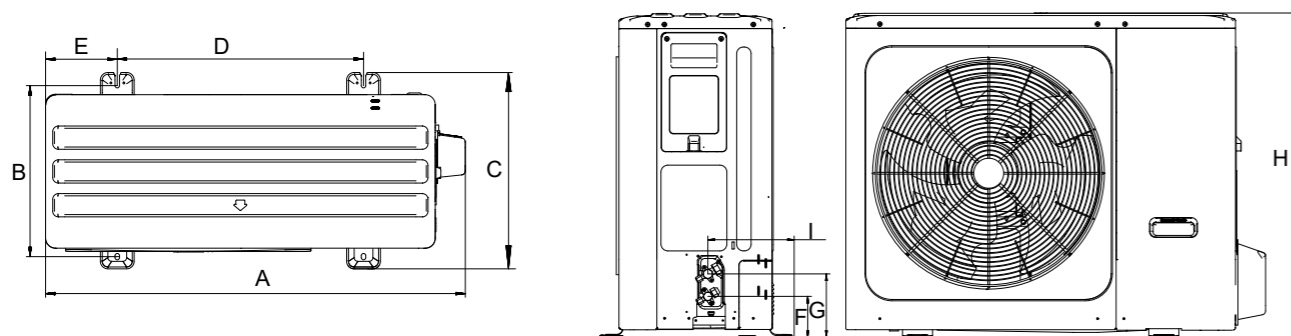

Model		MHA-V8W/D2N8-B MHA-V10W/D2N8-B	MHA-V12W/D2N8-B MHA-V14W/D2N8-B MHA-V16W/D2N8-B	MHA-V12W/D2RN8-B MHA-V14W/D2RN8-B MHA-V16W/D2RN8-B
Wymiary (dług./wys./głęb.)	mm	1118 / 865 / 523	1118 / 865 / 523	1118 / 865 / 523
Wymiary B/D/E	mm	456 / 656 / 191	456 / 656 / 191	456 / 656 / 191
Wymiary F/G/I	mm	110 / 170 / 230	110 / 170 / 230	110 / 170 / 230
Wymiary transportowe (dług./wys./głęb.)	mm	1180 / 970 / 560	1180 / 970 / 560	1180 / 970 / 560
Waga netto/brutto	kg	75 / 89	97 / 110,5	112 / 125,5

WYMIARY JEDNOSTEK WEWNĘTRZNYCH

M-Thermal Split

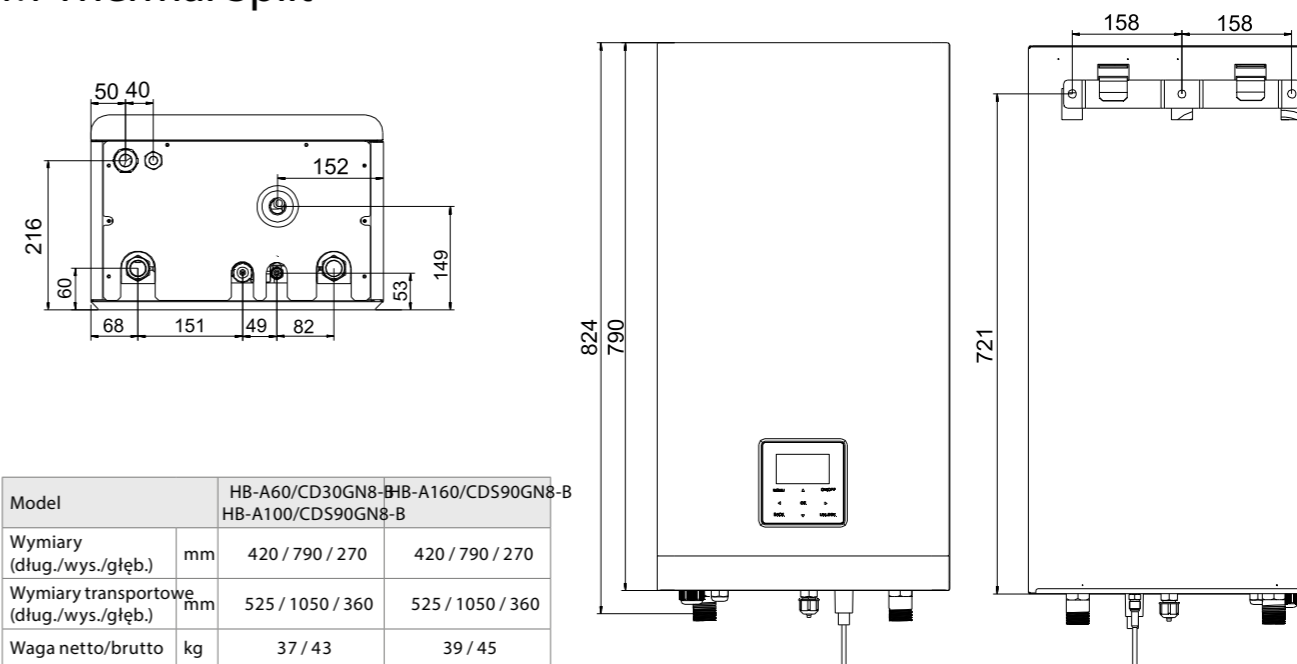

Model		HB-A60/CD30GN8-B HB-A100/CDS90GN8-B	HB-A160/CDS90GN8-B
Wymiary (dług./wys./głęb.)	mm	420 / 790 / 270	420 / 790 / 270
Wymiary transportowe (dług./wys./głęb.)	mm	525 / 1050 / 360	525 / 1050 / 360
Waga netto/brutto	kg	37 / 43	39 / 45

M-Thermal ALL IN ONE

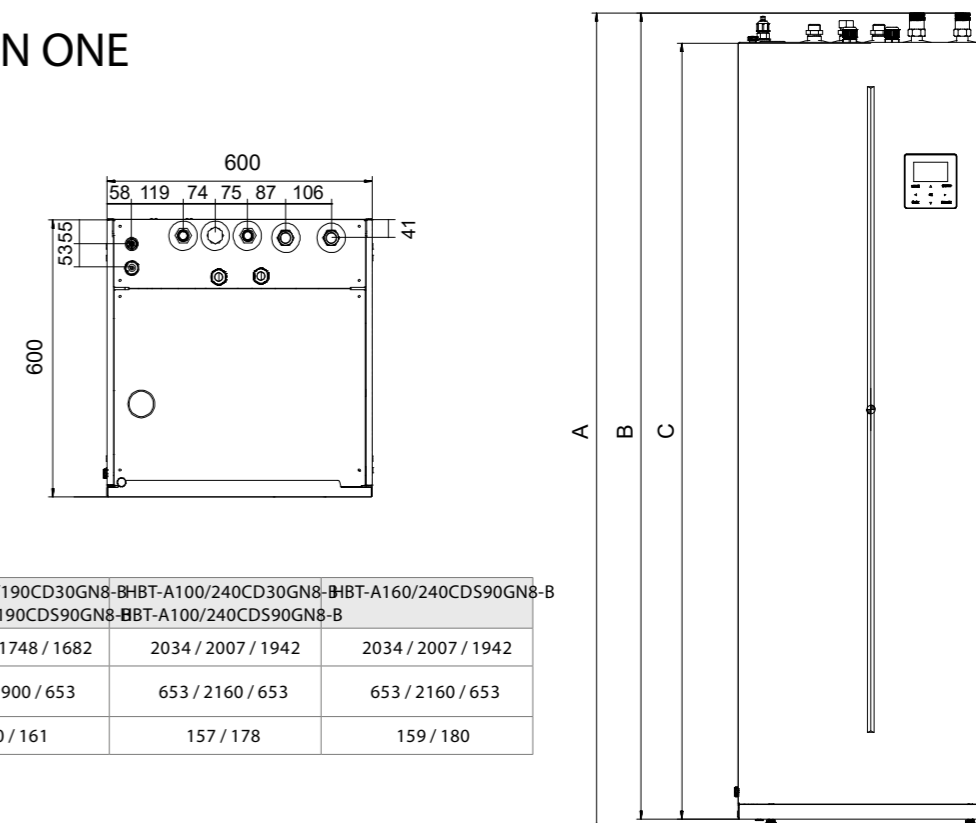

Model		HBT-A100/190CD30GN8-B HBT-A100/190CDS90GN8-B	HBT-A100/240CD30GN8-B HBT-A100/240CDS90GN8-B	HBT-A160/240CDS90GN8-B
A/B/C	mm	1775 / 1748 / 1682	2034 / 2007 / 1942	2034 / 2007 / 1942
Wymiary transportowe (dług./wys./głęb.)	mm	653 / 1900 / 653	653 / 2160 / 653	653 / 2160 / 653
Waga netto/brutto	kg	140 / 161	157 / 178	159 / 180